

## Фрезерование канавок

### Многозубые пластины

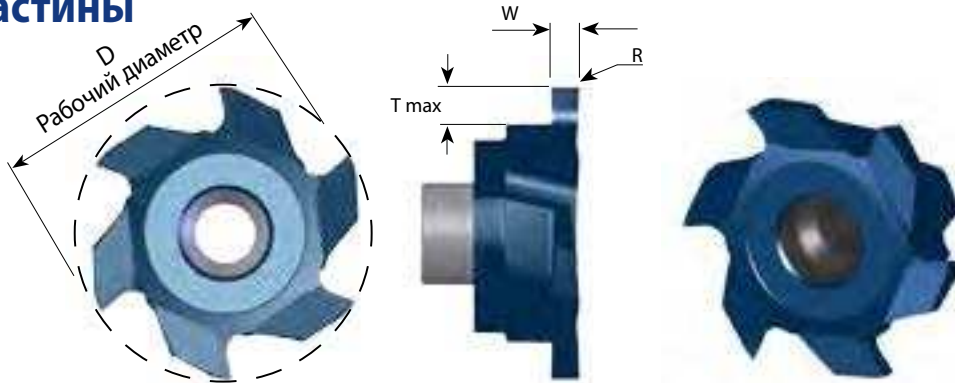

Тип пластины	Обозначение	D	W ±0.02	T Мах.	R	Мин. диаметр канавки	Кол-во зубьев	Корпус
S17	<b>SG170 F W15</b>	17.0	1.5	2.8	0.2	Ø > 17	6	H3, 4, 5, 14, 15
	<b>SG170 F W20</b>	17.0	2.0					
	<b>SG170 F W25</b>	17.0	2.5					
S20	<b>SG200 F W15</b>	20.0	1.5	2.9	0.2	Ø > 20	6	H6, 7, 8, 9, 16
	<b>SG200 F W20</b>	20.0	2.0					
	<b>SG200 F W25</b>	20.0	2.5					
	<b>SG200 F W30</b>	20.0	3.0					
	<b>SG200 F W40</b>	20.0	4.0					
	<b>SG200 F W49</b>	20.0	4.9					
S20	<b>SG200 E W20T</b>	20.0	2.0	3.7	0.2	Ø > 20	5	H16
	<b>SG200 E W25T</b>	20.0	2.5					
	<b>SG200 E W30T</b>	20.0	3.0					
S35	<b>SG350 F W30T</b>	35.0	3.0	6.3	0.2	Ø > 35	6	H19, 20, 21
	<b>SG350 F W40T</b>	35.0	4.0					
	<b>SG350 F W50T</b>	35.0	5.0					
	<b>SG350 F W60T</b>	35.0	6.0					
	<b>SG350 F W80T</b>	35.0	8.0					

\* Полное описание корпусов на стр. 193 и 194