

# D-Thread

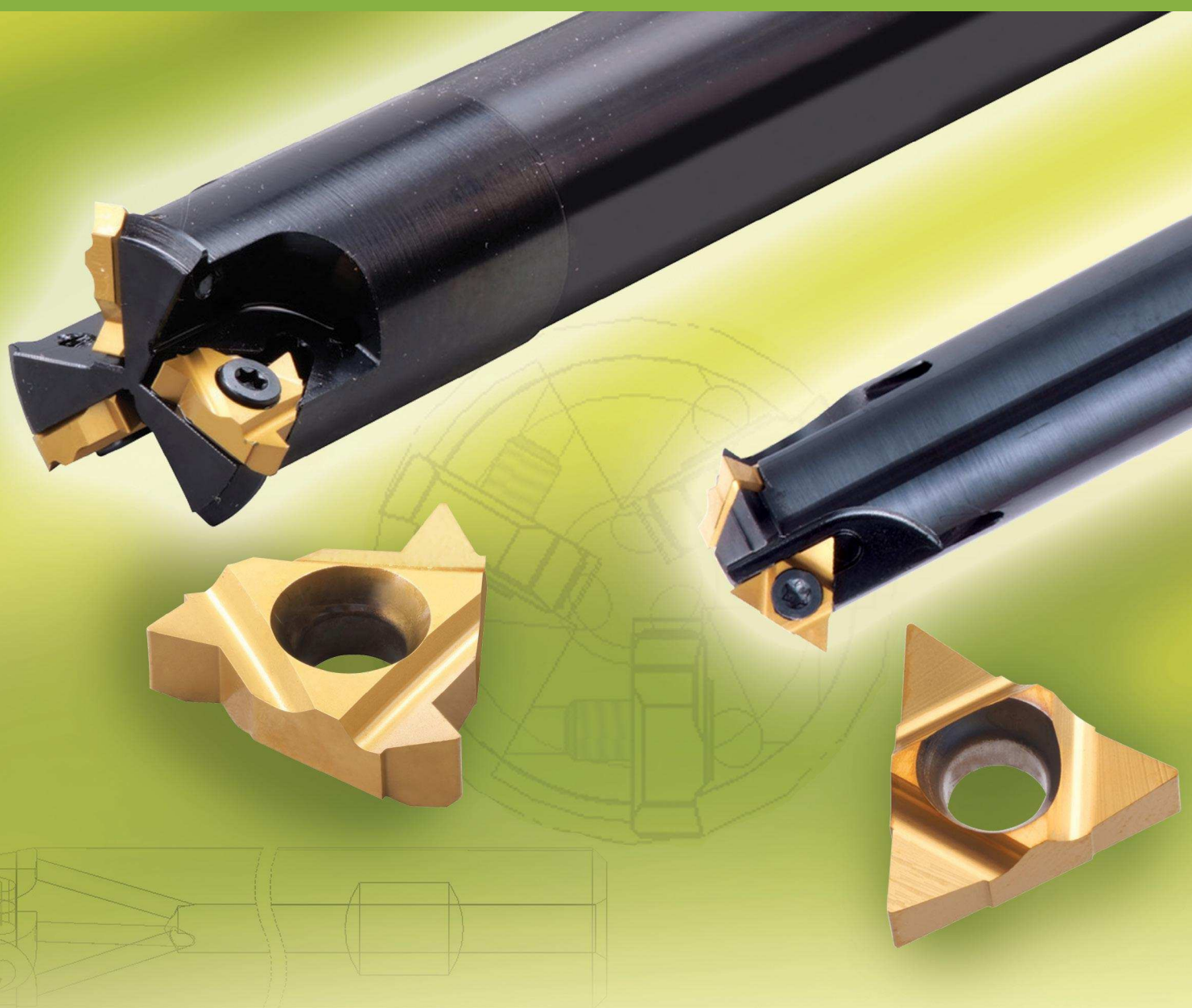

## Mill-Thread Inserts and Toolholders for machining deep threads

- Improved productivity due to multi-insert toolholders.
- Partial Profile, standard or U-type inserts for a wide range of threads.
- Inserts with three cutting edges, reduces tooling costs.
- Low cutting resistance due to the single point inserts.
- Holder allows for a long overhang and includes internal coolant.
- Same insert and toolholder for both external and internal thread.

### Contents:

### Page:

Standard Toolholders and Inserts  
U-Type Toolholders and Inserts

158  
159-160