

D-Thread Mill-Thread Inserts & Toolholders for machining deep threads

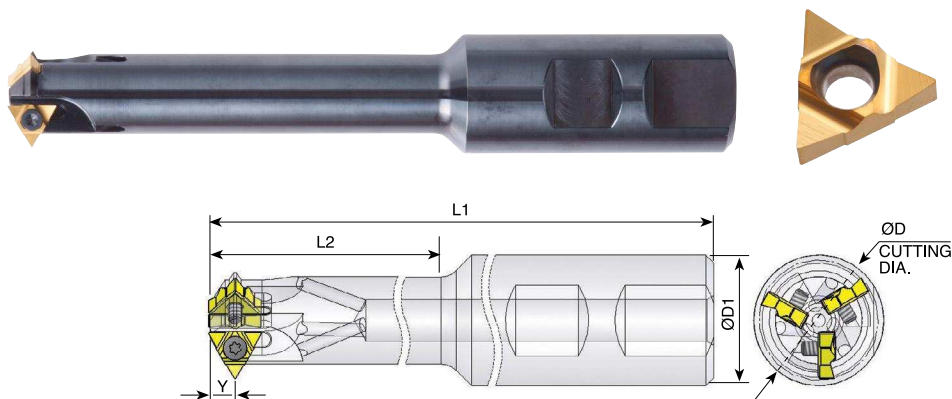

Ordering Code	Insert Size		Y	D	D1	L1	L2	No. of Inserts	Insert Screw	Torx Key
	L	I.C								
SR0023M11U	11U	1/4U	5	23	25	150	88	3	SE11	K11

Partial 60° Size 11U

Ordering Code		Pitch	
		mm	TPI
11U 60D	INT.	2.5 - 4.0	10 - 6
	EX.	2.0 - 3.0	12 - 8
11U 60D-18-12	INT.	1.5 - 2.0	18 - 12
	EX.	1.25 - 1.75	20 - 14

Coated Grade: BMA

Partial 55° Size 11U

Ordering Code		Pitch TPI
11U 55D	INT./EX.	12 - 7

