

Ordering Code	Insert Type	Insert size A	D	D1	L	No. of Inserts	Screw	Key
<b>SRH40-4</b>	H40	37	40	32	180	4	S45S	K40
<b>SRH45-6</b>	H45	37	45	32	130	6	S45	K40

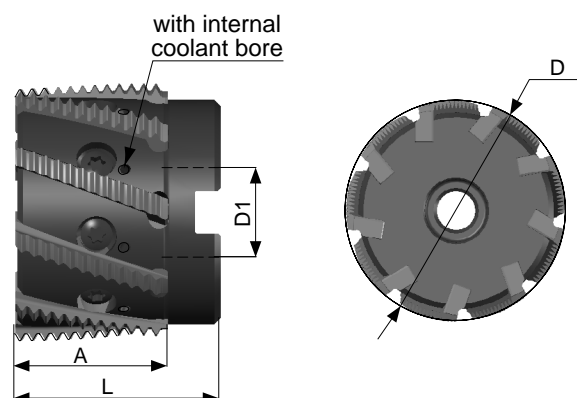

Ordering Code	Insert Type	Insert size A	D	D1	L	No. of Inserts	Screw	Key
<b>SRH32-5M</b>	H32	32	32	16	52	5	S32S	K22
<b>SRH45-6M</b>	H45	37	45	22	60	6	S45S	K40
<b>SRH63-9</b>	H63	38	63	22	50	9	S63	K40