

## Carmex presents a modular line of Mill-Thread toolholders

- Carmex modular holders are ideal for deep reach applications.
- Unique clamping method enables optimal strength and indexability.
- Cost saving - Same shank can hold different heads.
- Toolholders with internal coolant bore.
- Screw connection allows long overhang.
- Carmex standard thread milling inserts fit these toolholders.
- Different steel extensions are available.
- Toolholders are compatible with common toolholding systems.

### Toolholders

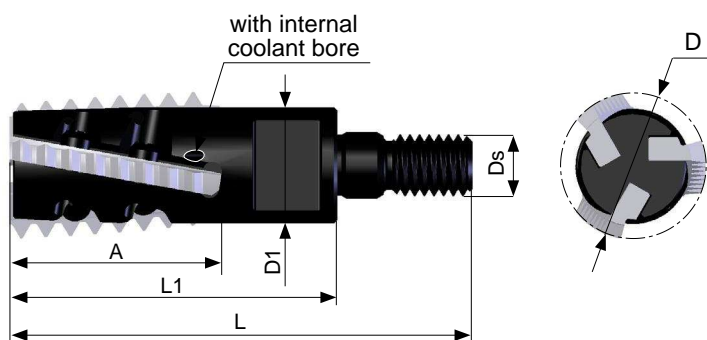

Ordering Code	Insert size A	D	D1	Ds	L1	L	No. of Inserts	Screw	Key
<b>SRH19-3 S</b>	27	19	15	M8	42.5	60	3	S19	K11

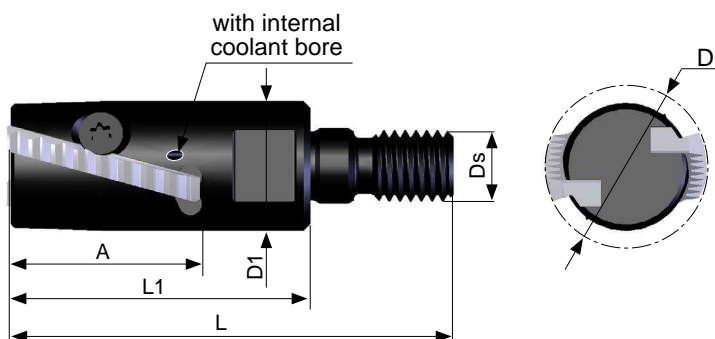

Ordering Code	Insert size A	D	D1	Ds	L1	L	No. of Inserts	Screw	Key
<b>SRH23-2 S</b>	27	23	18	M10	42.5	62.5	2	S23	K16