

Groove Milling

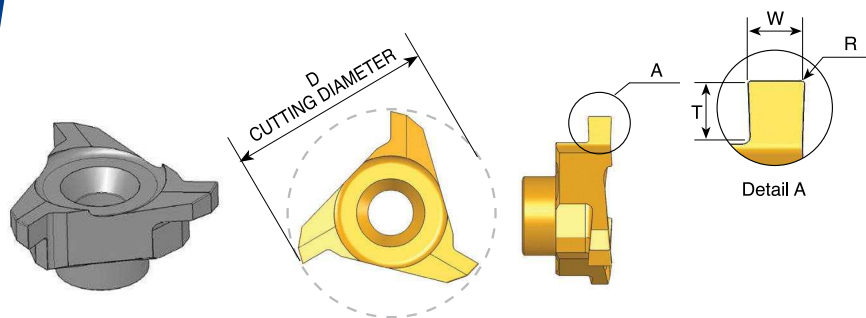

Insert Type	Ordering Code	D	W ±0.02	T max.	R	Groove Dia. (min.)	Holder Code
C10	C10 W08	10.0	0.80	0.80	0.1	Ø > 10.0	H1, 2, 12, 13
	C10 W09		0.90	0.90			
	C10 W10		1.00	0.90			
C12	C12 W08	12.0	0.80	0.80	0.1	Ø > 12.0	H3, 4, 5, 14, 15
	C12 W10		1.00	0.90			
C18	C18 W10	17.8	1.00	1.50	0.1	Ø > 17.8	H6, 7, 8, 9, 16
	C18 W12		1.20	1.50			
	C18 W15		1.50	1.95			
	C18 W20		2.00	2.80			H16
C25	C25 W20	25.0	2.00	3.00	0.2	Ø > 25	H10, 11, 17, 18
	C25 W25		2.50	3.00			
	C25 W30		3.00	3.00			
	C25 W35		3.50	3.50			
	C25 W40		4.00	3.50			
	C25 W50		5.00	3.50			

* For complete toolholder description see pages 193 and 194