

Groove Milling

Multi Flute

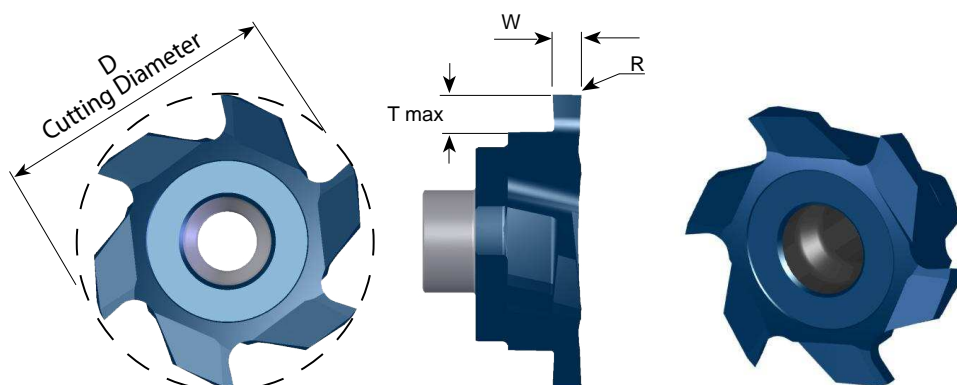

Insert Type	Ordering Code	D	W ±0.02	T Max.	R	Groove Dia. (min)	No. of Flutes	Holder Code
S17	SG170 F W15	17.0	1.5	2.8	0.2	Ø > 17	6	H3, 4, 5, 14, 15
	SG170 F W20	17.0	2.0					
	SG170 F W25	17.0	2.5					
S20	SG200 F W15	20.0	1.5	2.9	0.2	Ø > 20	6	H6, 7, 8, 9, 16
	SG200 F W20	20.0	2.0					
	SG200 F W25	20.0	2.5					
	SG200 F W30	20.0	3.0					
	SG200 F W40	20.0	4.0					
	SG200 F W49	20.0	4.9					
S20	SG200 E W20T	20.0	2.0	3.7	0.2	Ø > 20	5	H16
	SG200 E W25T	20.0	2.5					
	SG200 E W30T	20.0	3.0					
S35	SG350 F W30T	35.0	3.0	6.3	0.2	Ø > 35	6	H19, 20, 21
	SG350 F W40T	35.0	4.0					
	SG350 F W50T	35.0	5.0					
	SG350 F W60T	35.0	6.0					
	SG350 F W80T	35.0	8.0					

* For complete toolholder description see pages 193 and 194