

CMT Vertical Milling

Full Radius Groove Milling Multi Flute

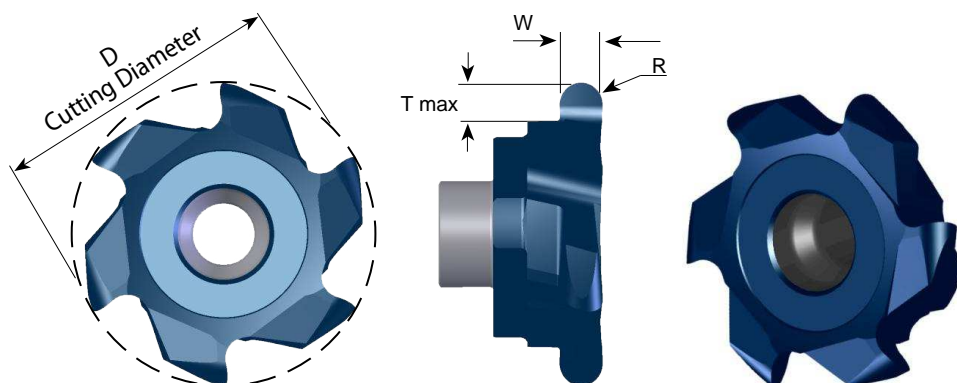

Insert Type	Ordering Code	D	R	W ±0.02	T Max.	Groove Dia. (min)	No. of Flutes	Holder Code
S20	SG200 F R10	20.0	1.0	2.0	2.9	Ø > 20	6	H6, 7, 8, 9, 16
	SG200 F R12	20.0	1.2	2.4				
	SG200 F R15	20.0	1.5	3.0				
	SG200 F R20	20.0	2.0	4.0				

Face Milling and Finishing

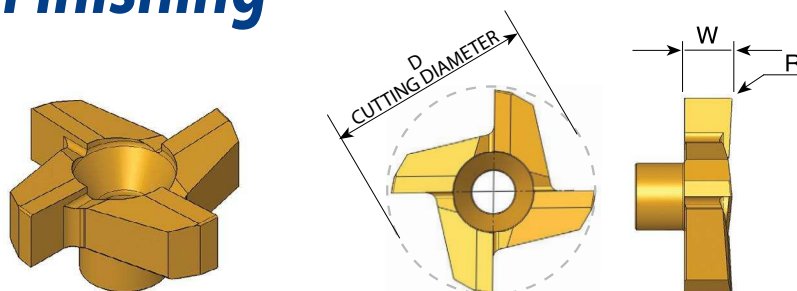

Insert Type	Ordering Code	D	W	R	Holder Code
C18	C18 F R0.1	17.8	5.0	0.1	H6, 7, 8, 9, 16
C25	C25 F R0.2	25.0	6.0	0.2	H10, 11, 17, 18

* For complete toolholder description see pages 193 and 194