

UN with internal coolant bore

Tools for Internal Thread

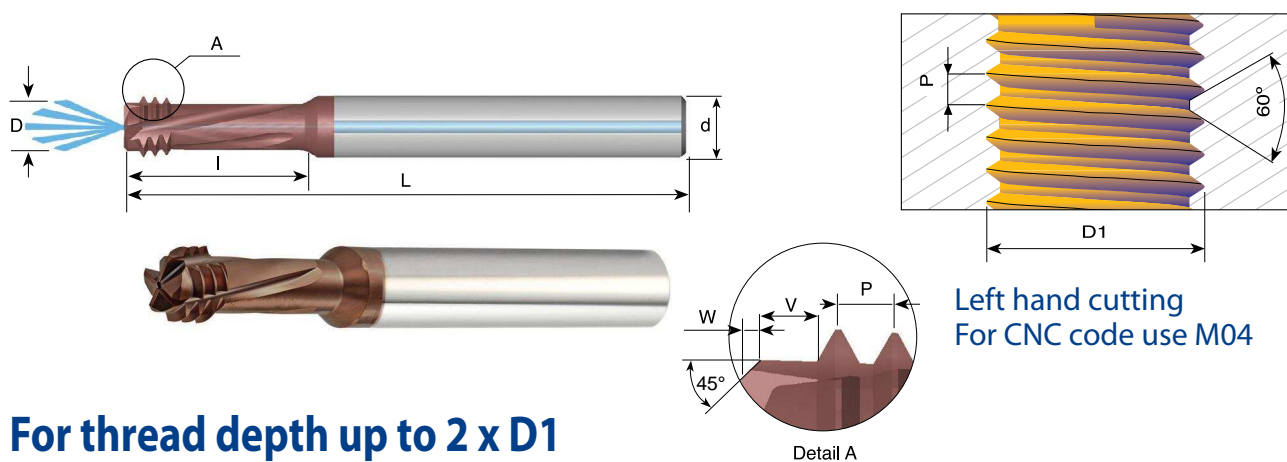

For thread depth up to 2 x D1

Pitch TPI	UN, UNEF, UNF UNC, UNS	Ordering Code	d	D	No. of Flutes	I	W	V	L
28	1/4 - 3/8	DMT 0805C14 28 UN	8	5.00	3	14.5	0.4	0.9	64
24	5/16 - 1/2	DMT 08065D17 24 UN	8	6.50	4	17.0	0.5	1.05	64
20	1/4 - 3/8	DMT 08048C14 20 UN	8	4.80	3	14.0	0.4	1.25	64
18	5/16 - 7/16	DMT 0806D17 18 UN	8	6.00	4	17.0	0.5	1.4	64
16	3/8 - 1/2	DMT 08067C22 16 UN	8	6.70	3	22.0	0.5	1.6	64

Order example: DMT 08067C 22 16 UN MT7

UN without internal coolant

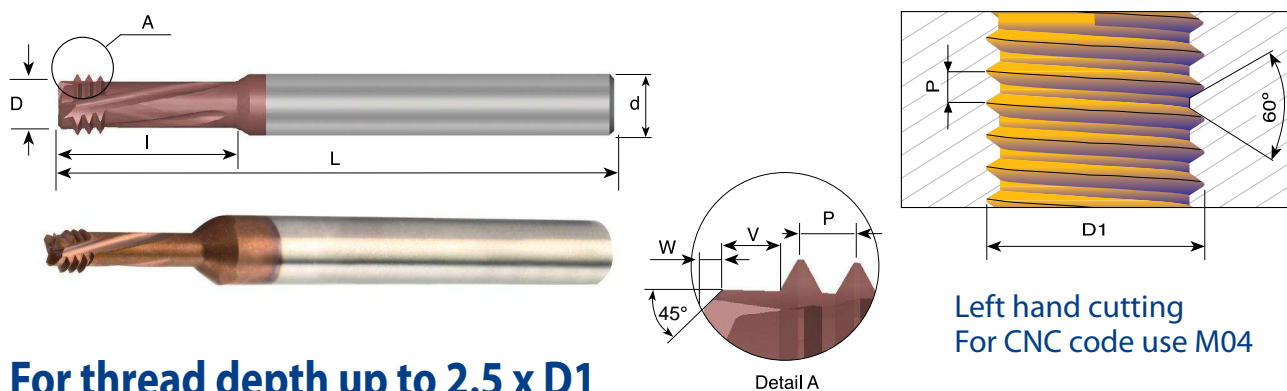

For thread depth up to 2.5 x D1

Pitch TPI	UNC	UNF	Ordering Code	d	D	No. of Flutes	I	W	V	L
36		8	DMT 06033C12 36 UN-D	6	3.30	3	12.0	0.2	0.7	58
32	8		DMT 06032C12 32 UN-D	6	3.20	3	12.3	0.3	0.8	58
32		10	DMT 06038C14 32 UN-D	6	3.80	3	14.0	0.3	0.8	58

Order example: DMT 06032C12 32UN-D MT7